

BM Series 5/2, 5/3 Way Pilot Solenoid Valve

22mm width

■ Features

1. Medium size, 22mm width solenoid valve, large flow rate.
2. Lockable manual override for easy operation.
3. Anodized aluminum body and strict quality control provide a long durability.
4. Coil nut is available, please refer to page 5-1.



■ How to order

BM520 X	—	O2	N	—	S	2	L	E1
520: 5/2 Way	Acting style	Port size	Thread	Solenoid	Voltage	Led	Coil type	
530: 5/3 Way	Blank: Standard	02: 1/4"	Blank: G	S: Single solenoid	1: 110VAC	Blank: W/O LED	Blank: DIN	
	5/3 Way	03: 3/8"	N :NPT	D: Double solenoid	2: 220VAC	L :W/I LED	F :Lead wire	
	Blank: Closed center	04: 1/2"	R :Rc		6: 24VAC		E1: EX-proof 22mm width	
	X: Exhaust center				7: 12VDC		E2: EX-proof 30mm width	
	Y: Pressurized center				9: 24VDC		E3: EX-proof CSA standard	

* Please refer to page 5-10 for the details of ex-proof coil.

■ How to order manifold

MFB520	—	O2	N	O2
	Port size	Thread	Stations	
	02: 1/4"	Blank: G	02 :2 Stations	
	03: 3/8"	N :NPT	03 :3 Stations	
	04: 1/2"	R :Rc	XX :XX Stations	

■ Specifications

Model	BM520-02-S(D)	BM530-02-D	BM520-03-S(D)	BM530-03-D	BM520-04-S(D)	BM530-04-D
Port size	1/4", 1/8" (Exhaust ports)		3/8", 1/4" (Exhaust ports)		1/2"	
Body material	Aluminum alloy					
Fluid	Compressed air					
Acting	Internal pilot					
Effective area	18mm ²	14mm ²	30mm ²	18mm ²	50mm ²	30mm ²
Operating pressure range	2~8 kgf/cm ²					
Proof pressure	9.9 kgf/cm ²					
Ambient temperature	-10℃ ~ 60℃					
Duty cycle	100% ED					
Coil type	DIN (Standard)					
Protection class	IP65 (DIN 40 050)					
Insulation class	F					
Voltage tolerance	±10%					
Standard voltage	220VAC, 110VAC, 24VDC (The other voltage is optional)					
Net weight	235g(335g)	445g	410g(500g)	700g	590g(720g)	770g

■ Dimensions

BM520-02-S

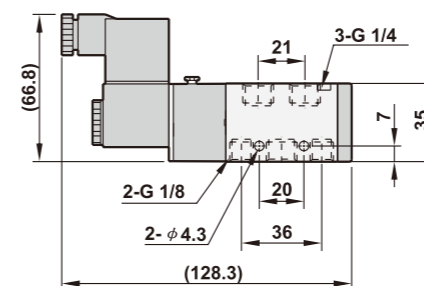
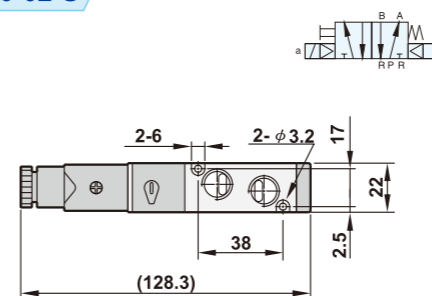

BM520-02-D

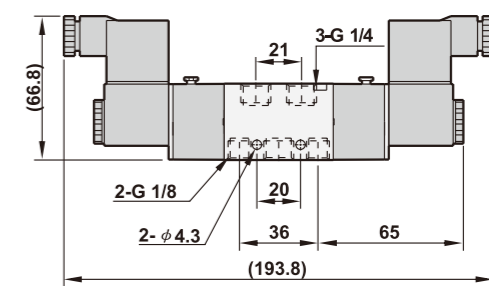
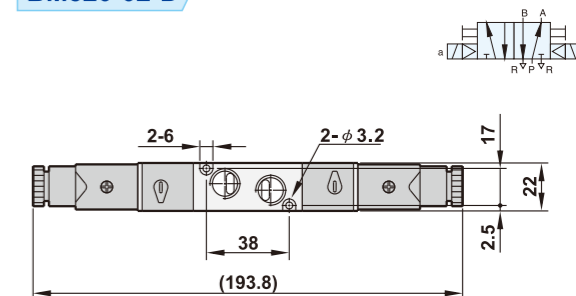

BM530(X)(Y)-02-D

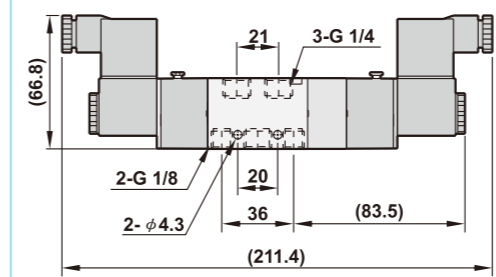
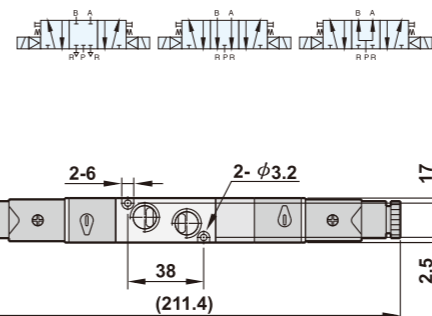

MFB520-0206

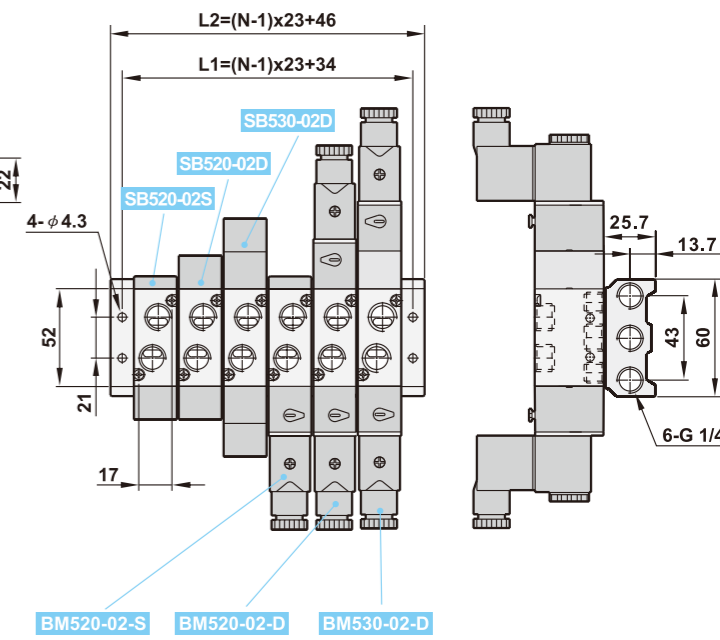

Number of station (N)	2	3	4	5	6	7	8	9	10
L1	57	80	103	126	149	172	195	218	241
L2	69	92	115	138	161	184	207	230	253

■ Dimensions

BM520-03-S

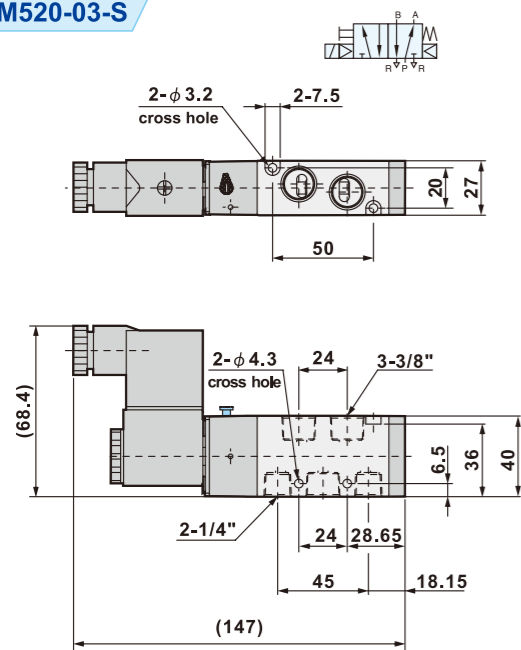

BM520-03-D

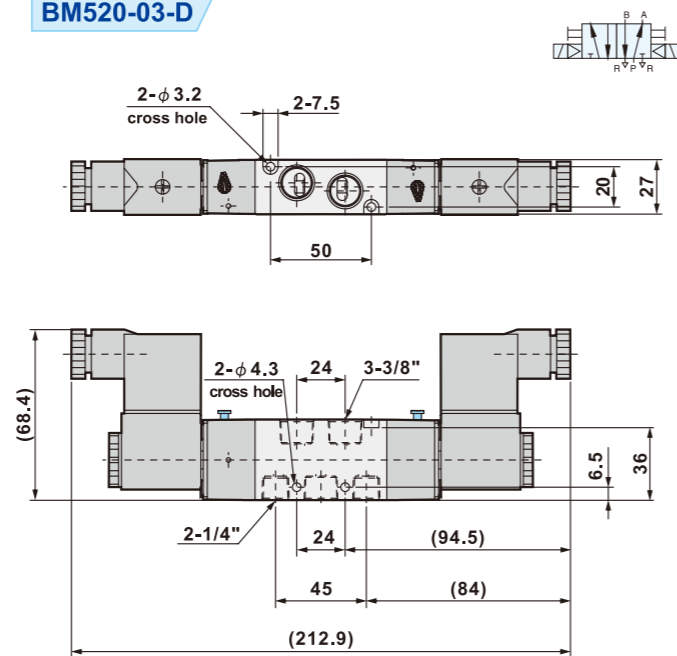

BM530(X)(Y)-03-D

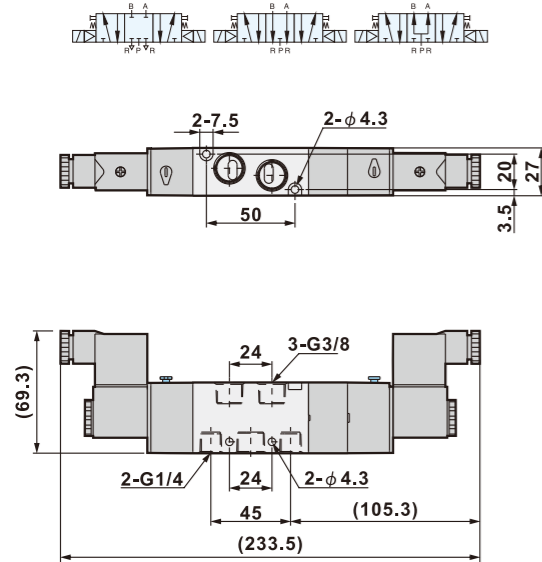

MFB520-0306

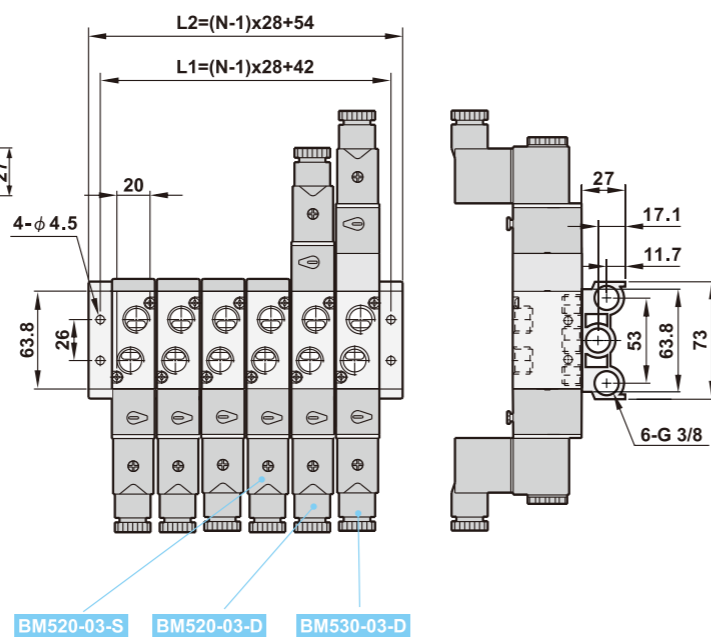

Number of station (N)	2	3	4	5	6	7	8	9	10
L1	70	98	126	154	182	210	238	266	294
L2	82	110	138	166	194	222	250	278	306

■ Dimensions

BM520-04-S

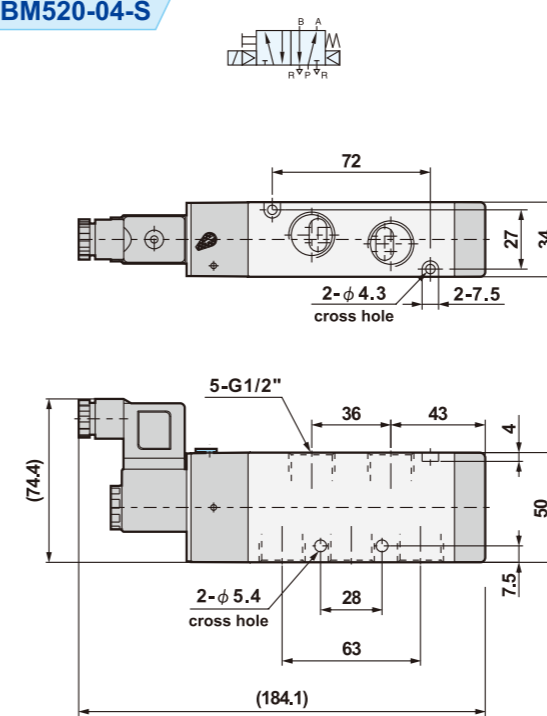

BM520-04-D

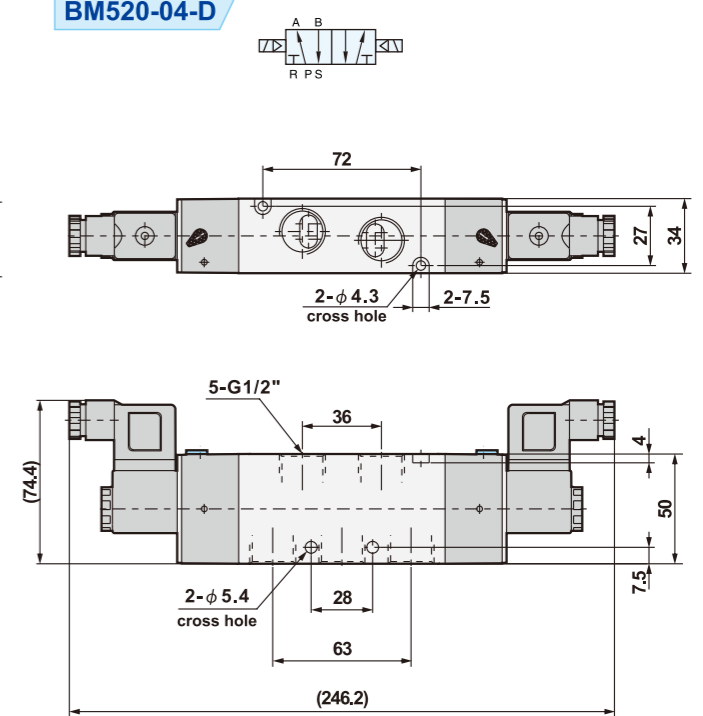

BM530(X)(Y)-04-D

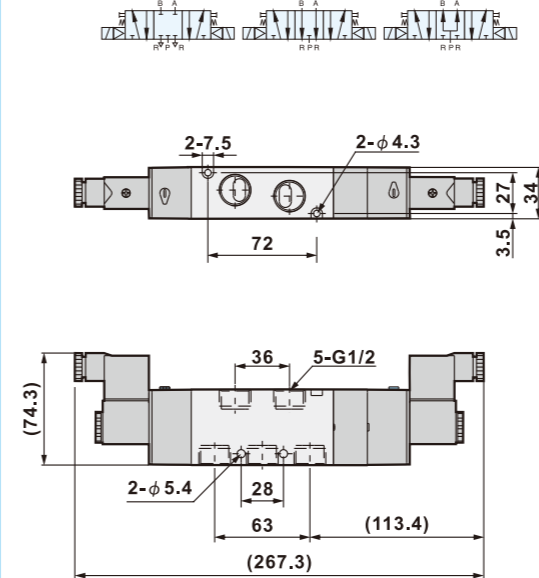

MFB520-0406

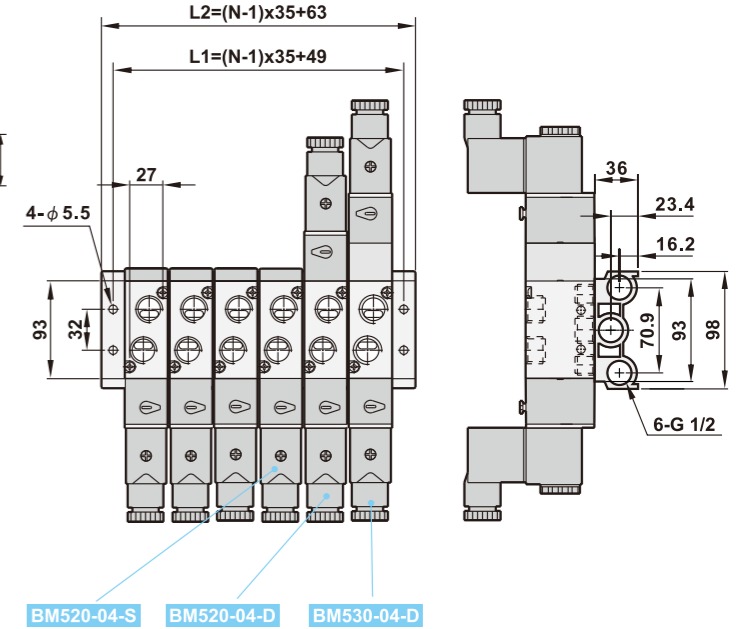

Number of station (N)	2	3	4	5	6	7	8	9	10
L1	84	119	154	189	224	259	294	329	364
L2	98	133	168	203	238	273	308	343	378