

Symbol



Features

- AD940 series effectively and quickly drains water.
- Special internal construction prevents vacuum occurred.



How to order

<b>AD940</b>	<b>-</b>	<b>04</b>	<b>N</b>	<b>A</b>
Automatic Drain	Port size	Thread	Bowl	
	04 : 1/2"	Blank : G	Blank : Standard bowl	
	06 : 3/4"	N : NPT	A : Anti-acid & Alkali bowl	
	08 : 1"	R : Rc	AL : Aluminum bowl	

Specifications

Model	AD940-04	AD940-06	AD940-08
Port size	1/2"	3/4"	1"
Fluid	Compressed air		
Body material	Aluminum die-cast		
Bowl material	Polycarbonate (Standard), Aluminum bowl (Option)		
Operating pressure range	0.5 ~ 10 kgf/cm <sup>2</sup>		
Proof pressure (Standard bowl)	12 kgf/cm <sup>2</sup>		
Ambient temperature	-10°C ~ 60°C		
Filter bowl capacity	105cc	210cc	
Net weight	500g (Al bowl 800g)	850g (Al bowl 1200g)	

Dimensions

AD940-04

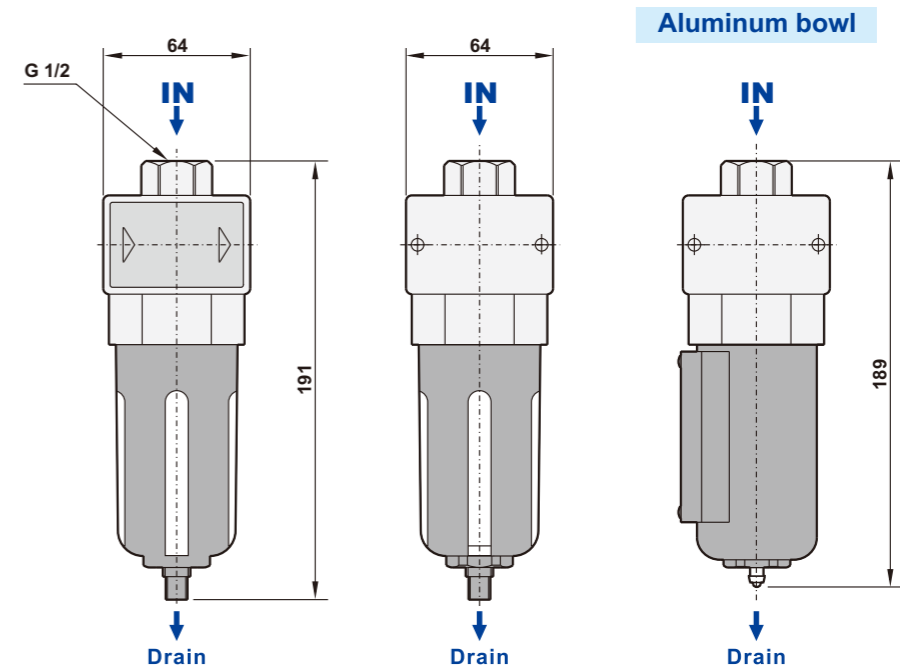

AD940-06, 08

